

904S

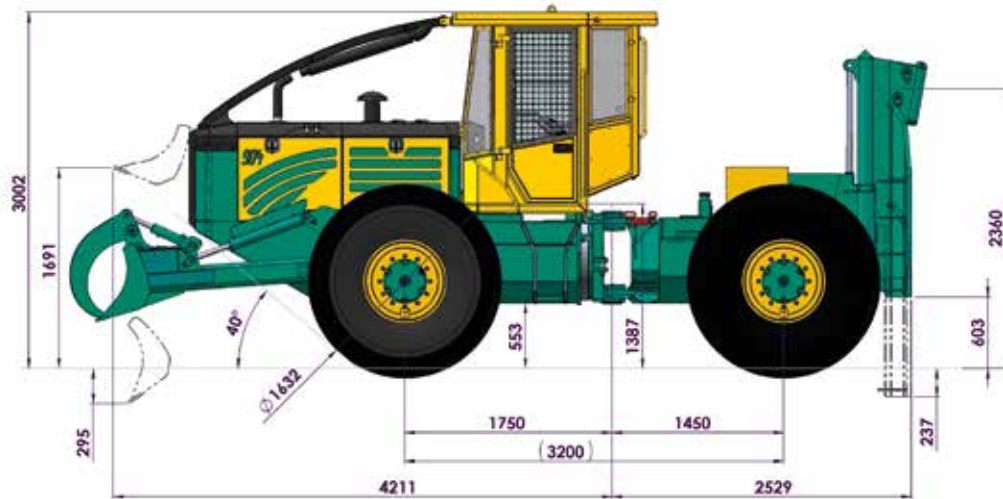

Engine:

- VOLVO PENTA**
 TAD581VE EU Stage V
 Power: 129 kW (175 HP) from 1700 rpm
 Max. revolution: 800 Nm from 1100 - 1500 rpm
 Max. torque: 816 Nm at 1380 rpm
 Displacement: 5,13 liters

Optional:

- VOLVO PENTA**
 TAD583VE EU Stage V
 Power: 175 kW (238 HP) from 1750 rpm
 Max. revolution: 947 Nm from 1200 - 1750 rpm
 Max. torque: 969 Nm at 1380 rpm
 Displacement: 5,13 liters

Transmission:

- HSM High Speed Drive (series 71)
- 2-step NAF transfer gearbox

Axles:

- NAF heavy duty planetary axles
- 100 % selectable differential locks

Brake:

- 2-circuit brake, wet disk brakes
- Spring-loaded parking brake

Steering:

- 44° articulated steering

Tyres:

- | | Size: | min. total width |
|-----------|-----------|------------------|
| Series: | 23,1 x 26 | 2550 mm |
| Optional: | 18,4 x 26 | 2300 mm |
| | 28L-26 | 2750 mm |

Tank capacity:

- Diesel: 185 l
- Hydraulics: 90 l
- AdBlue: 45 l

Hydraulic system:

- Pump output: Flow rate: 152 l/min at 1600 rpm
 Pressure: up to 350 bar
- Hydraulic liquid: Series: HLP-46 mineral oil
 Optional: Panolin HLP SYNTH with Kleenoil Microfiltration WGK 1

Cabin:

- Rubber-mounted, soundproofed
- Tested safety cab
- Mechanically suspended comfort seat
- Hot water heating

Electrics:

- 110 A (28 V) generator
- 2 maintenance-free dry-cell batteries

Instruments:

- Tachometer with operating hour counter, coolant temperature, tank gauge, indicator lights

Winch:

- Series: Adler HY 20-O (2 x 100 kN) double-drum winch
 Max. cable take-up 14 mm, 100 m without cable equipment!
- Optional: Adler HY 24-O (2 x 120 kN) double-drum winch
 Max. cable take-up 14 mm, 140 m
 Adler HY 24-LO (2 x 120 kN) double-drum winch
 Max. cable take-up 14 mm, 190 m
 Adler HY 32-O (2 x 160 kN) double-drum winch
 Max. cable take-up 14 mm, 150 m
 Adler HY 32-LO (2 x 160 kN) double-drum winch
 Max. cable take-up 14 mm, 190 m
 TCM 16+ (2 x 160 kN) double-drum winch
 Max. cable take-up 14 mm, 220 m

Weight:

- 10.800 kg (series)
- Weight distribution: Front axle: 60 %
Rear axle: 40 %

Standard equipment:

- 2200 mm wide front polder shield, lowerable straight shield
2200 mm wide, fire extinguisher, first-aid kit, warning triangle, tool set

Special equipment:

- Radio control, cable winch, wireless driving, clamping arms for Front shield, steering with joystick, street lighting set