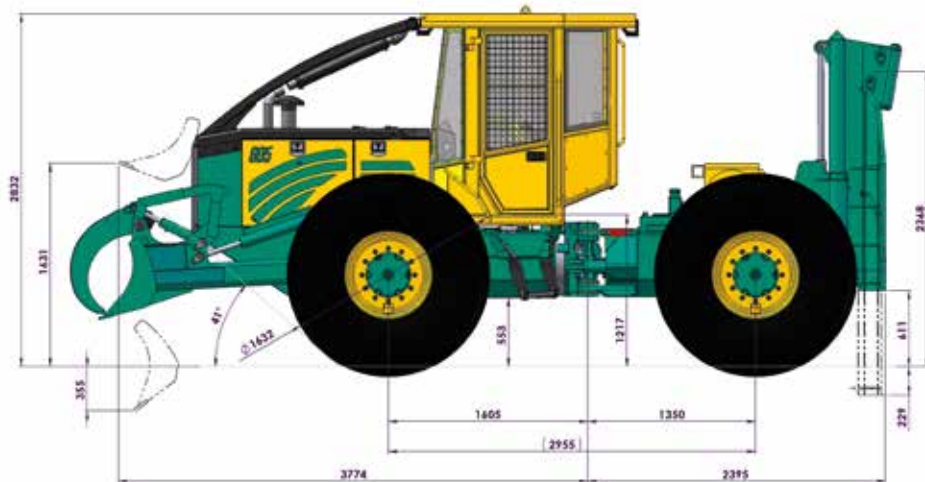

## 805S

**Engine:**

- DOOSAN 4-Zylinder  
D34 Stage V  
Power: 101 kW (135 HP) from 2200 rpm  
Max. torque: 500 Nm at 1400 rpm  
Displacement: 3,4 liters

**Transmission:**

- Hydrostatic transmission, Rexroth
- 2-step NAF transfer gearbox

**Axles:**

- NAF heavy duty planetary axles
- 100 % selectable differential locks

**Brake:**

- 2-circuit brake, wet disk brakes
- Spring-loaded parking brake

**Steering:**

- 44° articulated steering

**Tyres:**

- |           | Size:     | min. total width |
|-----------|-----------|------------------|
| Series:   | 23,1 x 26 | 2400 mm          |
| Optional: | 18,4 x 26 | 2200 mm          |
|           | 28L-26    | 2600 mm          |

**Tank capacity:**

- Diesel: 160 l
- Hydraulics: 90 l
- AdBlue: 25 l

**Hydraulic system:**

- Pump output: flow rate: 152 l/min at 1600 rpm  
pressure: up to 350 bar
- Hydraulic liquid: series: HLP-46 mineral oil  
optional: Panolin HLP SYNTH with Kleenoil  
Microfiltration WGK 1

**Cabin:**

- Rubber-mounted, soundproofed
- Tested safety cab
- Mechanically suspended comfort seat
- Hot water heating

**Elektrics:**

- 24 V, 80 A generator
- 2 maintenance-free dry-cell batteries

**Instruments:**

- Tachometer with operating hour counter, coolant temperature, tank gauge, indicator lights

**Winch:**

- Series: Adler HY 20-O (2 x 100 kN) double-drum winch  
Max. cable take-up 14 mm, 100 m  
without cable equipment!
- Optional: Adler HY 24-O (2 x 120 kN) double-drum winch  
Max. cable take-up 14 mm, 140 m  
Adler HY 24-LO (2 x 120 kN) double-drum winch  
Max. cable take-up 14 mm, 190 m  
Adler HY 32-O (2 x 160 kN) double-drum winch  
Max. cable take-up 14 mm, 150 m  
Adler HY 32-LO (2 x 160 kN) double-drum winch  
Max. cable take-up 14 mm, 190 m  
TCM 16+ (2 x 160 kN) double-drum winch  
Max. cable take-up 14 mm, 220 m

**Weight:**

- 9.300 kg (series)  
Weight distribution: Front axle: 60 %  
Rear axle: 40 %

**Standard equipment:**

- 2200 mm wide front polder shield, lowerable straight shield  
2200 mm wide, fire extinguisher, first-aid kit, warning triangle, tool set

**Special equipment:**

- Radio control, cable winch, wireless driving, clamping arms for Front shield, steering with joystick, road lighting set